

REV.	MODIFICATION	NAME	DATE

UNLESS OTHERWISE SPECIFIED:
 DIMENSIONS ARE IN MILLIMETERS
 SURFACE FINISH: Ra 0.8
 TOLERANCES: ±0.1mm

MATERIAL:
 CREATED DATE: mercredi 25 novembre 2009 20:04:46
 FOLDER NAME : D:\DOCKER\edocker\plan d'ensemble edocker

TITLE: **e Docker**
general dimensions

DESIGNED BY:

 52 rue de la croix de Molphey
 21410 AGEY
 FRANCE

LERAT Olivier
 TEL : 0033(0)3 80 23 69 20
 com-une.idee@orange.fr

DWG NO. _____
 SCALE: 1:2
 A3
 PAGE 1 OF 2

UNDER VIEW : scale 1/1

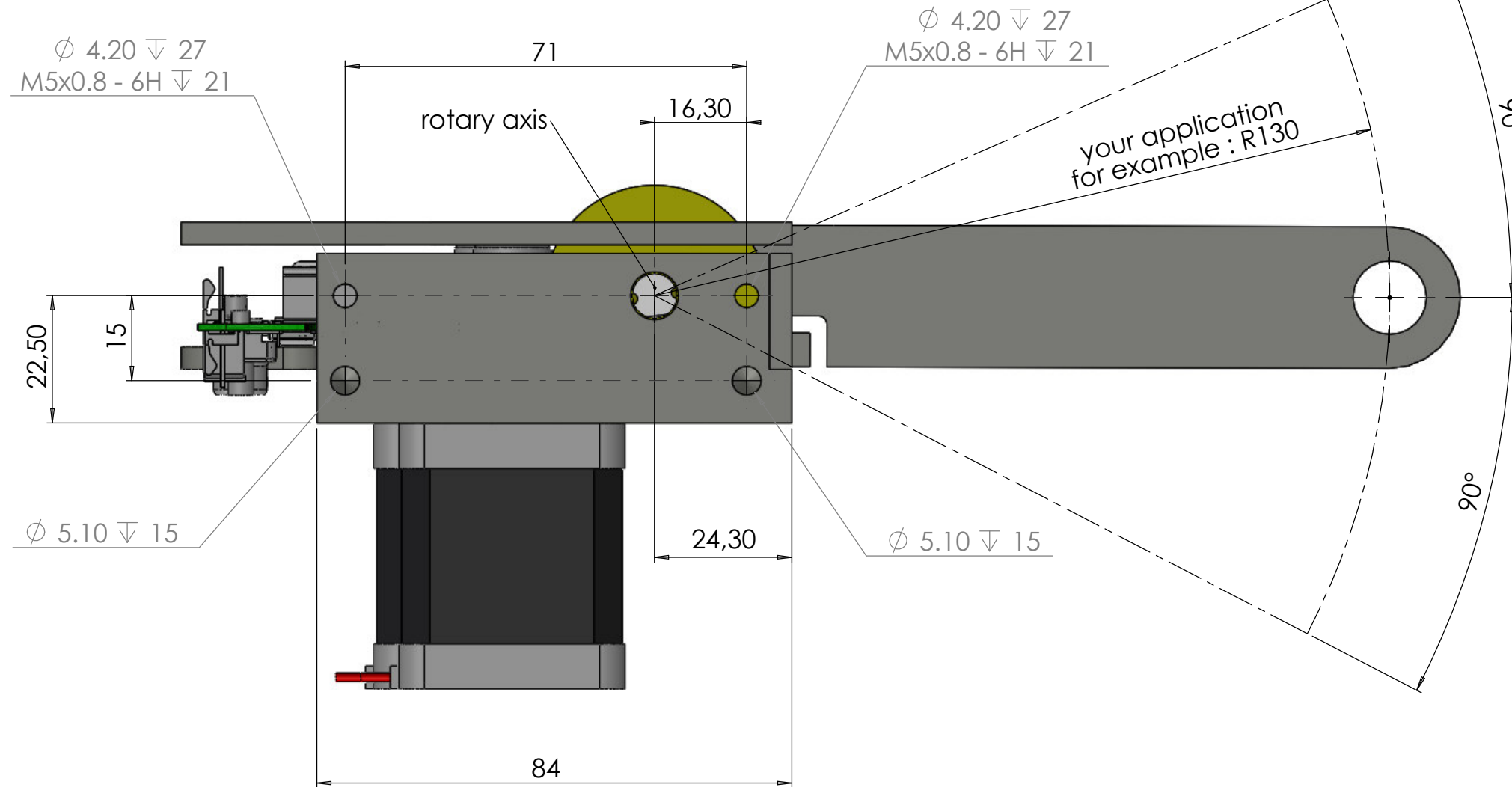

detail : arm fastening

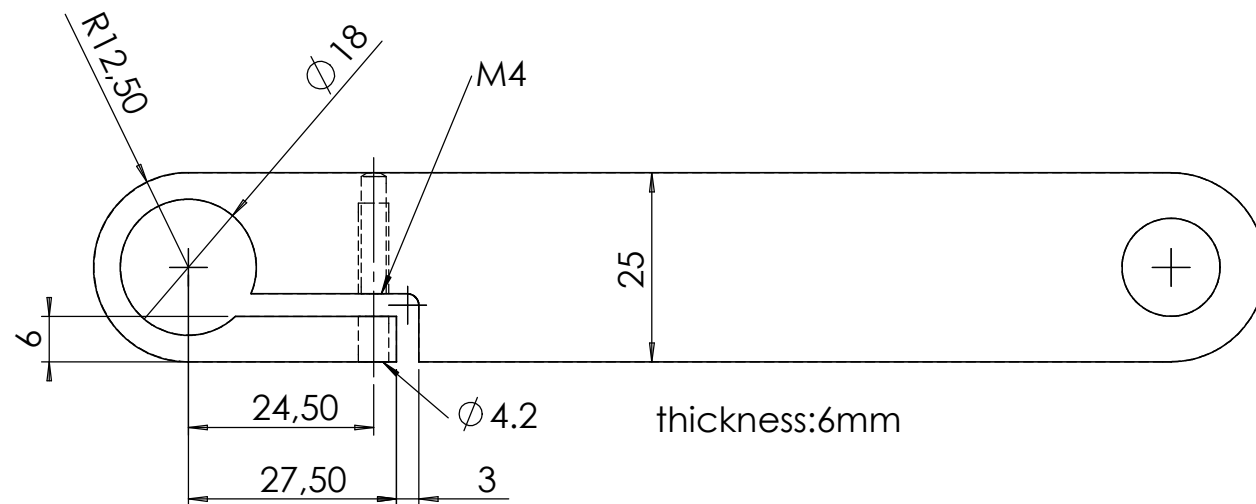

				DESIGNED BY:
				idconcept
				52 rue de la Croix de Molphey 21410 AGEY FRANCE
				LERAT Olivier
				TEL : 0033(0)3 80 23 69 20
				com-une.idee@orange.fr
REV.	MODIFICATION	NAME	DATE	
UNLESS OTHERWISE SPECIFIED: DIMENSIONS ARE IN MILLIMETERS SURFACE FINISH: Ra 0.8 TOLERANCES: ±0.1mm				
MATERIAL:				
CREATED DATE: mercredi 25 novembre 2009 20:04:46				
FOLDER NAME : D:\DOCKER\edocker\plan d'ensemble edocker				
TITLE:				
e Docker general dimensions			DWG NO.	A3
			SCALE:1:1	PAGE 2 OF 2